

PM 25H
Pile Driving Rig

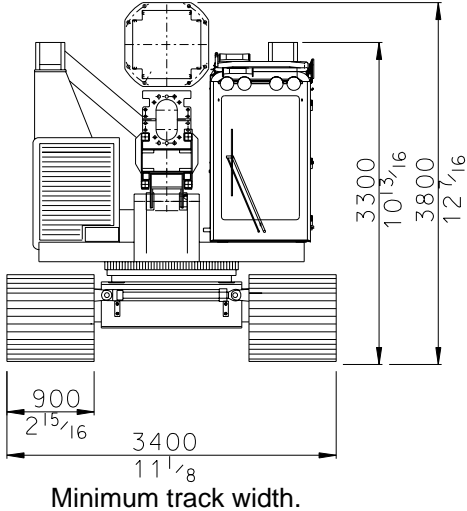

Minimum track width.

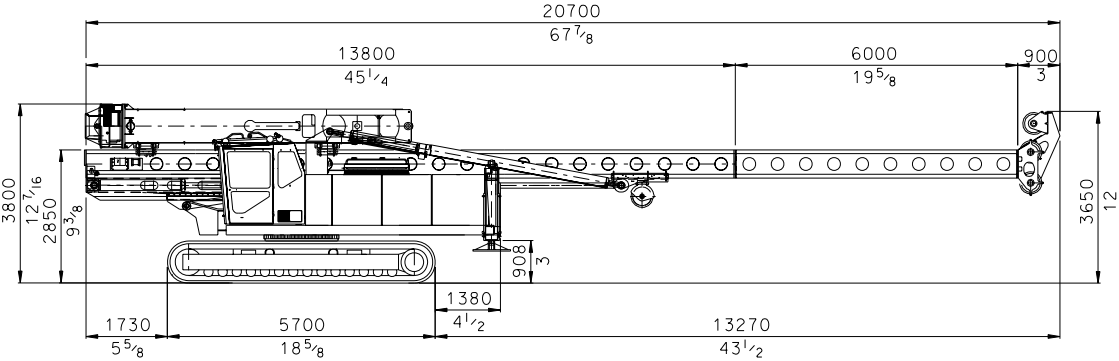

Standard PM 25H transport dimensions with HHK 7A hammer.

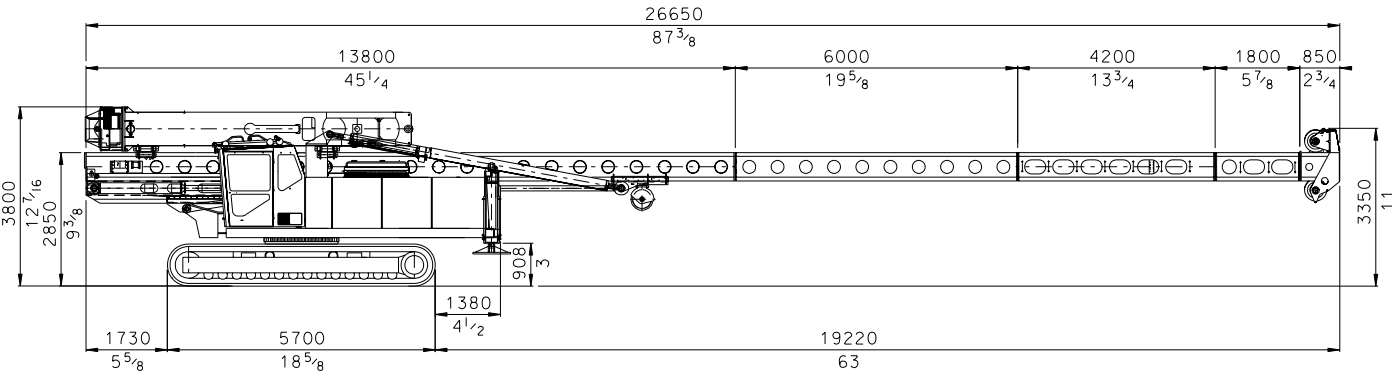

PM 25H transport dimension with extension leader, HHK 7A hammer and side cathead.

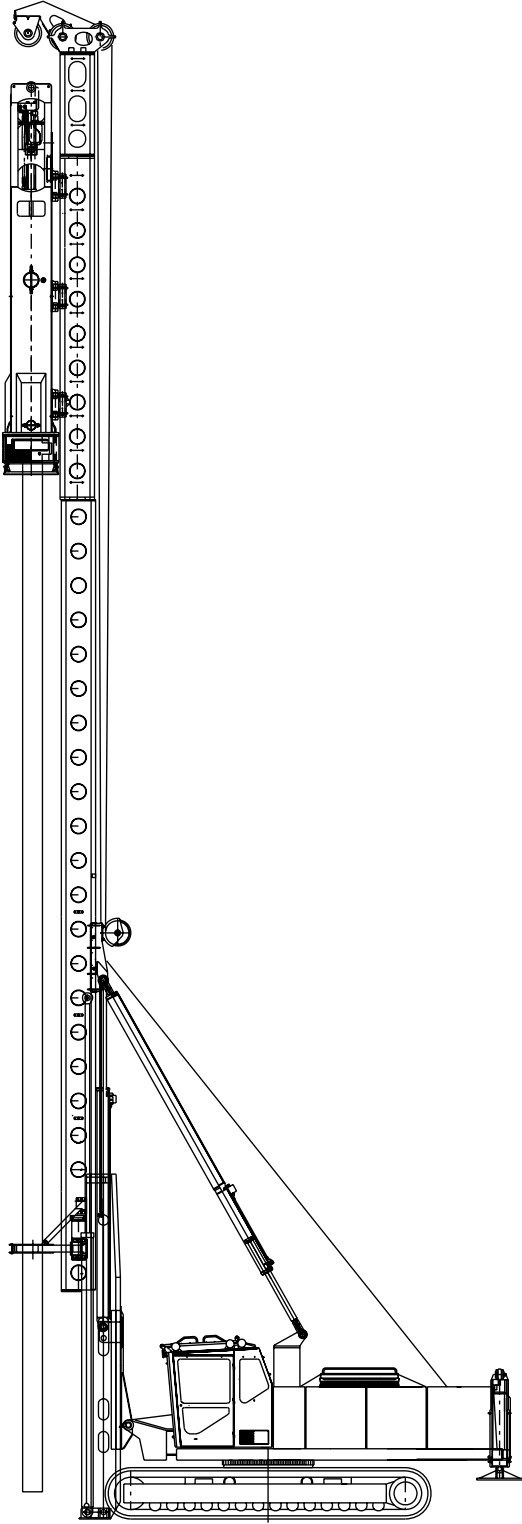

Junttan Oy reserves the right to amend the specification without prior notice. Error and misprints reserved. 18 September 2009 - version M125H003.

General Information

Junttan PM 25H is a medium weight piling rig designed for pile driving steel and concrete piles. PM25H is PM25's big brother. It is more powerful for heavy duty use. The rig has excellent stability and wide leader inclination angles. The recommended hammer weight is from 5 000 to 9 000 kg and the maximum pile length is 24 meters (79 ft). The rig has proven productivity. The telescopic leader ensures easy and fast handling of piles. Top pile driving performance is guaranteed with Junttan hydraulic hammers. An optional side drill or vibrator hammer makes pile driving even more efficient in some soil conditions. Versatility of the rig can be increased with additional drilling equipment. With optional Junttan equipment, optimised working set-up of the rig can be easily achieved.

This Junttan piling rig has the same proven Junttan features. Its rugged design makes it a safe and reliable rig even in the most demanding working conditions. The self-erecting leader and many advanced technical features ensure that the rig is ready to work in just a few minutes. The ergonomic and safety tested cabin allows the driver to concentrate completely on his work. The expandable tracks and low centre of gravity make the rig exceptionally stable in different working situations. The horizontal movement of the leader ensures fast spotting of the pile. In spite of larger size the rig can be still easily transported to a new working site.

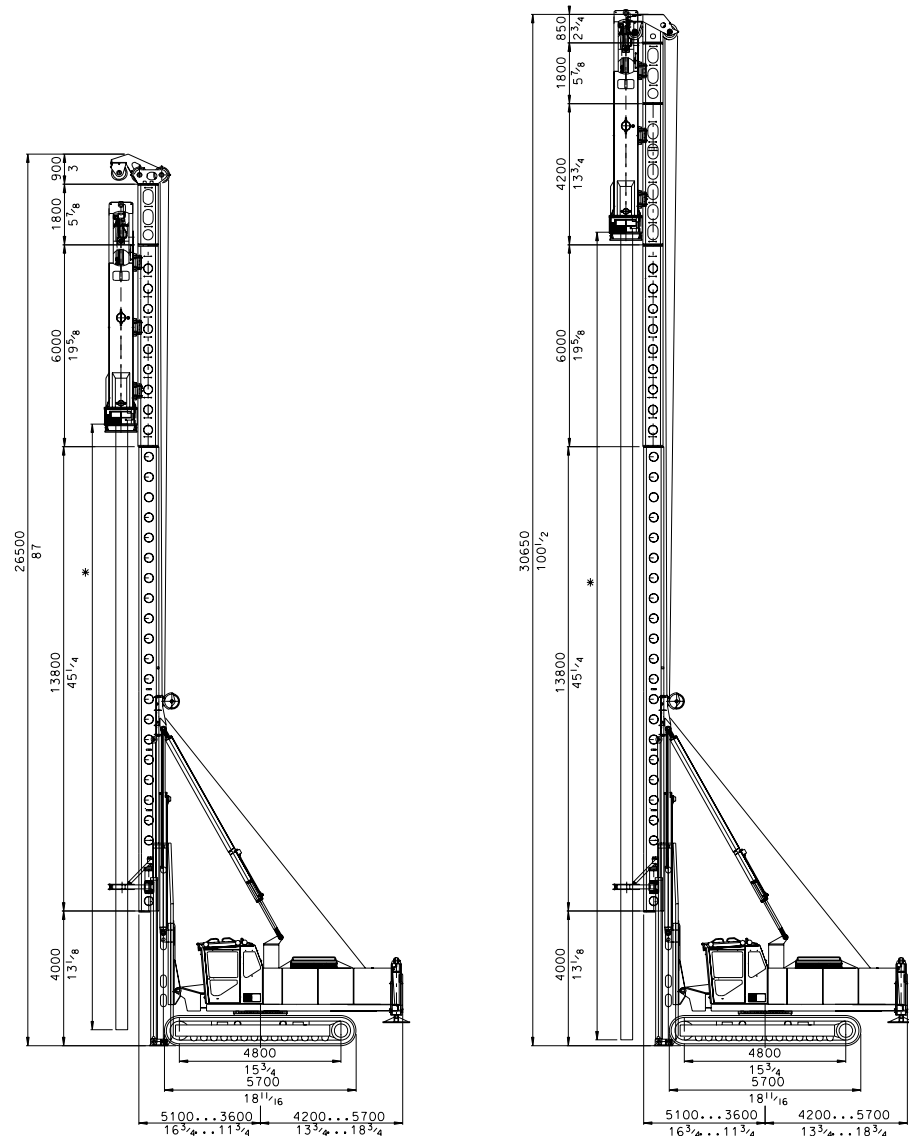

Standard PM 25H with HHK 7A hammer for pile driving

PM 25H with leader extension and HHK 7A hammer for pile driving

* Pile length depends on the hammer. See the table of hydraulic hammers beside.

Technical Data

Leader			
Type	KE 259302		
Length	Leader sections	m (ft)	13.8+6+1.8 (45 1/4 + 19 5/8 + 5 7/8)
	Total Length	m (ft)	26.5 (87)
Maximum capacity (pile+hammer)		kg (lb)	20 000 (44 000)
Movements	Vertical movement up/down	mm (inch)	1000/500 (40/20)
	Horizontal movement max.	mm (inch)	1500 (59)
	Inclinations	According to a separate capacity table	
Others	Hydraulic pile arms on leader Electronic leader inclinometer		

Uppercarriage			
Winches	(single line pull, 1. layer)		
	Main winch (hammer)	kg (lb)	15 000 (33 000)
	Aux. winch (pile)	kg (lb)	10 000 (22 000)
Engine	Make and Model Cummins QSM11		
	Max. power	kW (hp)	298 (400)
	Fuel tank volume	l (gal)	420 (110)
	Hydraulics	Hydraulic oil tank volume	l (gal)
	Max. oil flow	l/min (gpm)	2x 280 + 120 at 2000 rpm (2x 73 + 31 at 2000 rpm)
	Max. pressure	bar (psi)	320 (4640)
Counterweight	Weight	kg (lb)	6000+2000+2000 (13 230+4 410+4 410)

Undercarriage			
Type	AV 258901		
	Crawler length	mm (ft)	5700 (18 11/16)
	Min. width	mm (ft)	3400 (11 1/8)
	Max. width	mm (ft)	4400 (14 7/16)
	Triple grouser type track shoes	mm (ft)	900 (2 15/16)

Transport dimensions			
	Length	m (ft)	20.7 (67 7/8)
	Width	mm (ft)	3400 (11 1/8)
	Height	mm (ft)	3800 (12 7/16)
	Total weight	kg (lb)	58 000 (127 600)
(excluding hammer, counterweight and any additional equipment)			

Optional equipment	
• Leader hinge	• Leader foot plate
• Leader extension 1.8m (6 ft) ... 6 m (20 ft)	• Energy measuring device
• Side cathead	• Break heating
• Undercarriage max. width 5.1 m (16 3/4 ft)	• Aux. II winch 5 000 kg (11 000 lb)
• Track shoes 1100mm (3 5/8 ft)	• Flat track shoes
• Class cover	• Narrow track shoes 800 mm (2 1/2 ft)
• Side drill (JD 3)	• HD-crawler 5050 mm (17 ft)
• Stabilizers (rear legs)	• Side board
• Air conditioning for cabin	• Other accessories available on request

Approvals	
Manufactured according to EN 996 standard	

Hydraulic hammer examples for Junttan PM 25H					
Model		HHK 5A	HHK 7A	HHK 7S	HHK 9A
Max. energy	kNm (ft-lbs)	59 (43 600)	82 (60 600)	103 (76 000)	106 (78 300)
Stroke	m (ft)	0.05-1.2 (3/16-3 15/16)	0.05-1.2 (3/16-3 15/16)	0.05-1.5 (3/16-4 15/16)	0.05-1.2 (3/16-3 15/16)
Blows (adjustable)	per min	40-100	40-100	40-100	40-100
Ram weight	kg (lb)	5 000 (11 020)	7 000 (15 430)	7 000 (15 430)	9 000 (19 840)
Total weight including drive cap	kg (lb)	8 600 (18 960)	11 200 (24 690)	12 500 (27 560)	13 400 (29 540)
Pile length without leader extension	m (ft)	19 (62)	18 (59)	17 (56)	16 (52)