



Drive Cap Systems

Two styles of drive cap systems are available to meet a wide variety of pile driving applications.

- 1** The Universal Drive Cap Assembly provides a lightweight package for driving the basic H pile sections and popular pipe piles sizes using a single drive cap casting. Universal Drive Caps are available with guiding for 8" x 21" and 8" x 27" lead sizes.
- 2** The Primary Drive Cap and Insert Assembly provide a flexible package for driving a wide variety of piling sections. Primary Drive Caps are available with guiding for 8" x 21", 8" x 27", 8" x 32", and 8" x 43" leads. Drive Cap Inserts are available for use with H piling, pipe piles, timber piles, sheet piling, and concrete piles.

Universal and Primary Drive Cap Assemblies include a striker plate and hammer cushion sets comprised of aluminum and conbest disks.

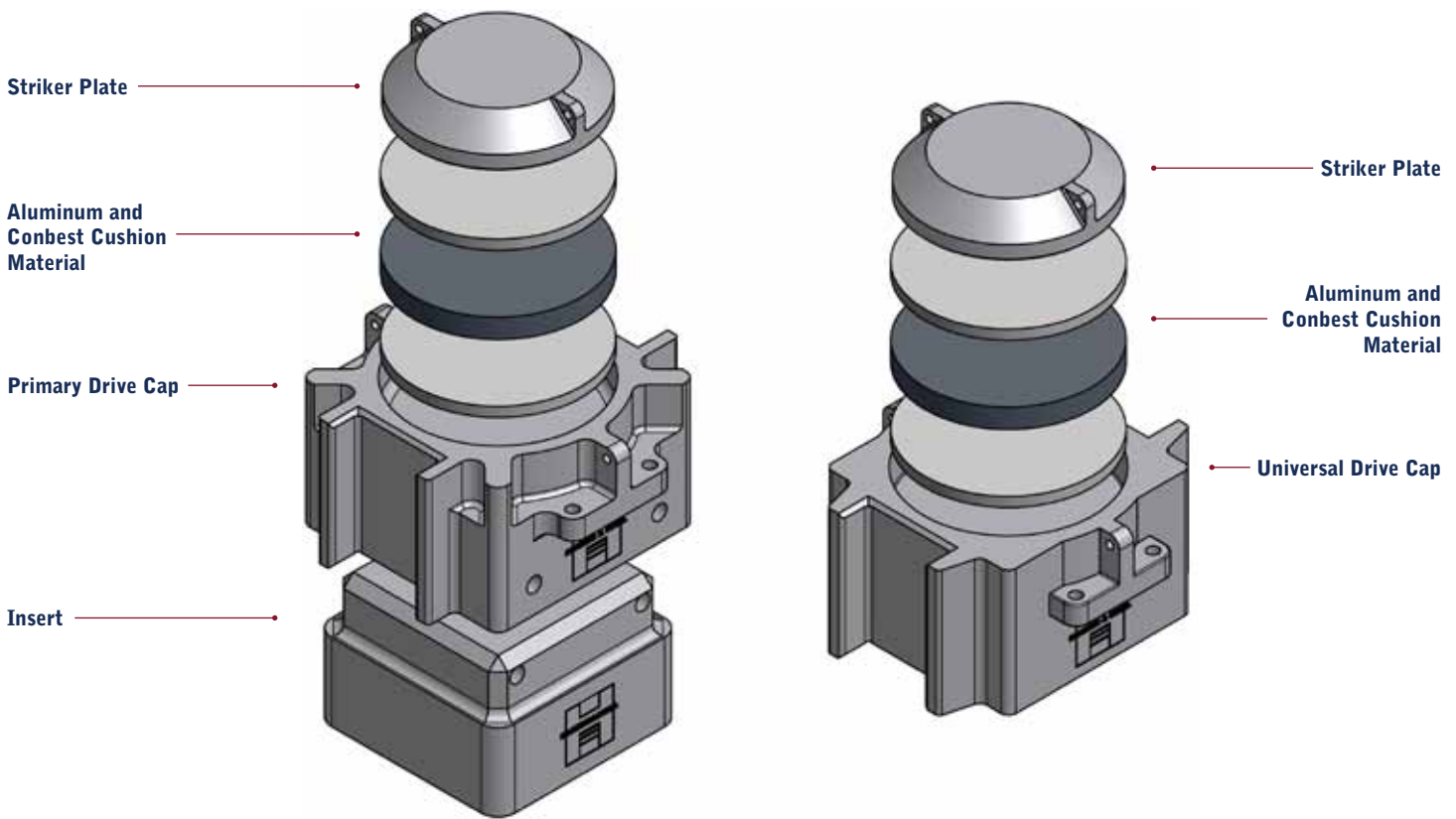

Primary Drive Cap & Insert Assembly

Universal Drive Cap Assembly



HAMMER & STEEL, INC.

Piling • Pile Driving Equipment • Drilling Equipment

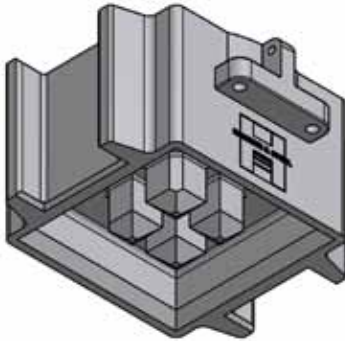

8' x 21' Universal Drive Cap

Drive Cap Casting	1015 lb.
Striker Plate	214 lb.
Aluminium Cushion 2 x 1/2" Thick, 17" Dia., 227.0 in ²	22 lb.
Conbest Cushion 1 x 1" Thick, 17" Dia., 227.0 in ²	11 lb.
Total Assembly	1262 lb.

Notes

- Guiding for 8" x 21" Tubular Leads
- Suitable for 10"/ 12"/ 14" H-Piling and 12"/14" Pipe Piling

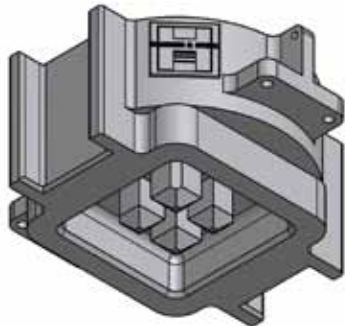

8' x 27' Universal Drive Cap

Drive Cap Casting	1650 lb.
Striker Plate	652 lb.
Aluminium Cushion 2 x 1/2" Thick, 23" Dia., 415.5 in ²	40 lb.
Conbest Cushion 1 x 1" Thick, 23" Dia., 415.5 in ²	20 lb.
Total Assembly	2362 lb.

Notes

- Guiding for 8" x 27" Tubular Leads
- Suitable for 10"/ 12"/ 14" H-Piling and 12"/14" Pipe Piling

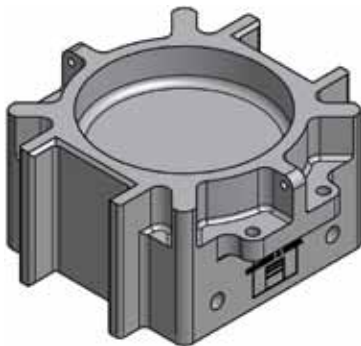

8' x 21' Primary Drive Cap

Drive Cap Casting	957 lb.
Striker Plate	214 lb.
Aluminium Cushion 2 x 1/2" Thick, 17" Dia., 227.0 in ²	22 lb.
Conbest Cushion 1 x 1" Thick, 17" Dia., 227.0 in ²	11 lb.
Total Assembly	1204 lb.

Notes

- Guiding for 8" x 21" Tubular Leads



HAMMER & STEEL, INC.

Piling • Pile Driving Equipment • Drilling Equipment

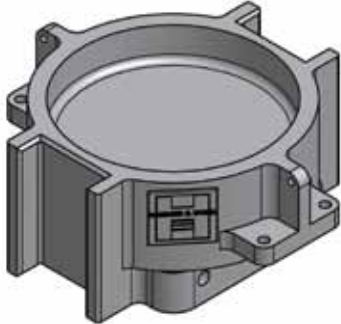

8" x 27" Primary Drive Cap

Drive Cap Casting	1515 lb.
Striker Plate	652 lb.
Aluminium Cushion 2 x 1/2" Thick, 23" Dia., 415.5 in ²	40 lb.
Conbest Cushion 1 x 1" Thick, 23" Dia., 415.5 in ²	20 lb.
Total Assembly	2209 lb.

Notes

- Guiding for 8" x 27" Tubular Leads

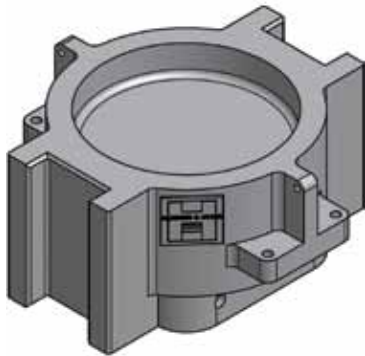

8" x 32" Primary Drive Cap

Drive Cap Casting	2913 lb.
Striker Plate	652 lb.
Aluminium Cushion 2 x 1/2" Thick, 23" Dia., 415.5 in ²	60 lb.
Conbest Cushion 1 x 1" Thick, 23" Dia., 415.5 in ²	40 lb.
Total Assembly	3665 lb.

Notes

- Guiding for 8" x 32" Tubular Leads

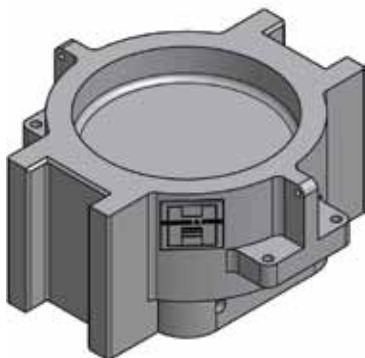

8" x 43" Primary Drive Cap

Drive Cap Casting	3030 lb.
Striker Plate	1050 lb.
Aluminium Cushion 2 x 1/2" Thick, 25" Dia., 490.9 in ²	48 lb.
Conbest Cushion 1 x 1" Thick, 25" Dia., 490.9 in ²	24 lb.
Total Assembly	4152 lb.

Notes

- Guiding for 8" x 43" Tubular Leads



Striker Plates

Striker Plate - 21" Drive Caps, 4" Thick, 17" Dia., 227.0 in ²	214 lb.
Striker Plate - 27" / 32" Drive Caps, 6-1/2" Thick, 23" Dia., 415.5 in ²	652 lb.
Striker Plate - 43" Drive Cap, 8" Thick, 25" Dia., 490.9 in ²	1050 lb.



HAMMER & STEEL, INC.

Piling • Pile Driving Equipment • Drilling Equipment

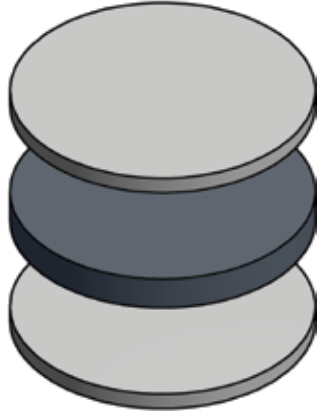

Cushion Material

Aluminium Disks 2 x 1/2" Thick, 17" / 23" / 25" Dia.	11 / 20 / 24 lb.
Conbest Disks 1 x 1" Thick, 17" / 23" / 25" Dia.	11 / 20 / 24 lb.

Notes

- Co-Efficient of Restitution = 0.80
- Modulus of Elasticity (PSI) = 408,000

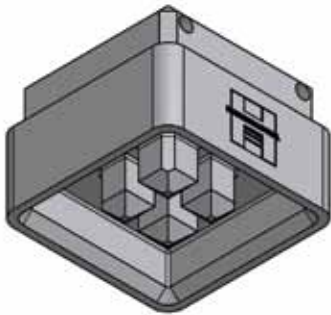

H-Piling Insert

H-Piling Insert	930 lb.
-----------------	---------

Notes

- Suitable for 10" / 12" / 14" H-Piling and 12"/14" Pipe Piling



12" - 36" Concrete Piling Inserts

12" Concrete Piling Insert (min. lead size = 21")	1544 lb.
14" Concrete Piling Insert (min. lead size = 21")	1588 lb.
16" Concrete Piling Insert (min. lead size = 21")	1749 lb.
18" Concrete Piling Insert (min. lead size = 27")	2314 lb.
20" Concrete Piling Insert (min. lead size = 27")	2858 lb.
24" Concrete Piling Insert (min. lead size = 32")	5635 lb.
30" Concrete Piling Insert (min. lead size = 43")	6927 lb.
36" Concrete Piling Insert (min. lead size = 43")	10823 lb.

Notes

- Cavity depth for 12", 14", 16" and 20" inserts = 16"



HAMMER & STEEL, INC.

Piling • Pile Driving Equipment • Drilling Equipment

- Cavity depth for 24", 30" and 36" inserts = 20"

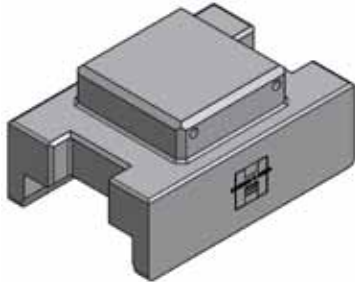

Sheet Piling Insert SSP1

Sheet Piling Insert SSP1	1727 lb.
Driving Land Length	32.3"
Driving Land Width	17.1"

Notes

- Can be used with 8" x 27" Leads

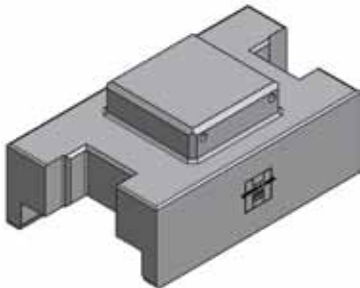

Sheet Piling Insert SSP2

Sheet Piling Insert SSP2	2933 lb.
Driving Land Length	39.6"/45.7"
Driving Land Width	19.3"

Notes

- Can be used with 8" x 32" Leads

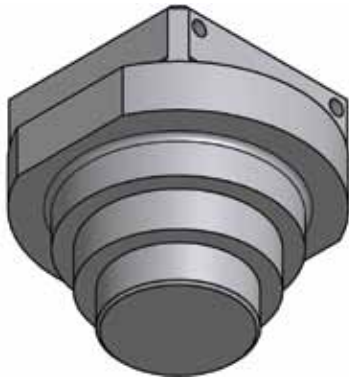

Pipe Piling Insert

Pipe Piling Insert - 21", for Piling Sizes up to 20" o.d.	1478 lb.
Pipe Piling Insert - 27", for Piling Sizes up to 24" o.d.	2242 lb.