

## ***DeltaBase 102***

Anchor drill rig, for double-head drilling systems,  
rotary/percussion operations





# The advantages DeltaBase 102

## DeltaBase 102

### The new Generation of Anchor Drilling Units

**Boart Longyear** belongs to the leading specialists worldwide in the development and manufacture of anchor drilling systems for the tunneling and special ground engineering construction.

**Boart Longyear** equipment range includes: hydraulic drilling equipment, hydraulic drifter, drilling accessories and highpressure injection system (Jet grouting systems).

Numerous patents, particularly in the area of drilling accessories, are proof of the strength of our powers of innovation and technical knowledge.

The progressive, cost-optimised and reliable use of **Boart Longyear** drill units and accessories provide excellent support to a smooth operating in the most varied building locations in projects all over the world.

The **DeltaBase 102** for double-head drilling system is a complete new **Boart Longyear** anchor drill rig. The new design of articulation with the rotatable and slewing jib boom is a unique feature of this machine.

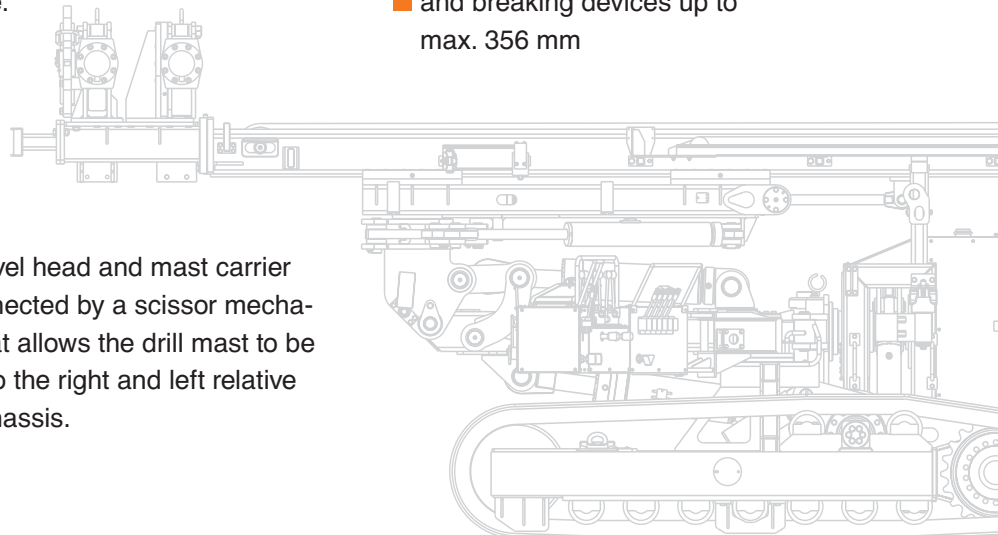

The swivel head and mast carrier are connected by a scissor mechanism that allows the drill mast to be turned to the right and left relative to the chassis.

The technical design for the anchor drilling provides an extendable mast. This makes it possible to drill even in restrictive local conditions.

The machine is equipped with a modern load sensing hydraulic system. The fulfillment of the anti-pollution law in force COM2 and EPA2 is one of the characteristic features of the new **DeltaBase 102**.

The pendulum crawler and the sound proof insulating cover are standard.

**Length: 7170 mm**  
**Width: 2280 mm**  
**Height: 2710 mm**  
**Weight: 13.900 kg**  
without drilling accessories

#### The drilling process and range of application:

- Hydraulic drifter up to  $We=1200$  (Nm)
- Rotary head up to 3200 daNm
- Double head drilling units:
  - Rotary/Rotary and
  - Rotary/Percussion
  - Various & hydraulic clamping
- and breaking devices up to max. 356 mm

### Advantages:

- Compact design
- Minimized center height
- Ergonomical control panel
- Control position with free view of the drilling
- Up-to-date load-sensing hydraulics
- Newly designed support for the articulation
- Compact double-head drilling unit
- Extendable drill mast



### Accessories (optional):

- Cable winch up to 35 kN pull
- Water pump delivering up to 200 l/min
- Compressed air lubricator for DTH hammer
- Rod handling system
- Loading crane
- Compressor
- Generator
- High pressure washing unit
- Jet grouting chuck up to 133 mm diameter
- Mast extensions up to 18 m total mast length (with geothermal articulation)

### Base unit:

- DEUTZ BF6M2012C drive power unit group 6 cylinder
- Hydraulics module
- 24 V DC electrical system
- Power controlled piston pump with load sensing system
- Clamping and breaking devices for max. 254 mm casing (standard version)
- Rotary head / drifter / double-head drilling unit
- Pendulum undercarriage B2
- Towing coupling on the rig end

### At a glance:

- Length: 7170 mm
- Width: 2280 mm
- Height: 2710 mm
- Mast length (max): 6000 mm inclusive carrier extension
- Transport weight: 13,900 kg without drilling equipment
- Crawler carriage: Type B2



*Newly designed double-head unit*



*DEUTZ Diesel with electronic engine control (EMR)*



# Kinematics DeltaBase 102

## DeltaBase 102

Flexible in relation to drilling positions

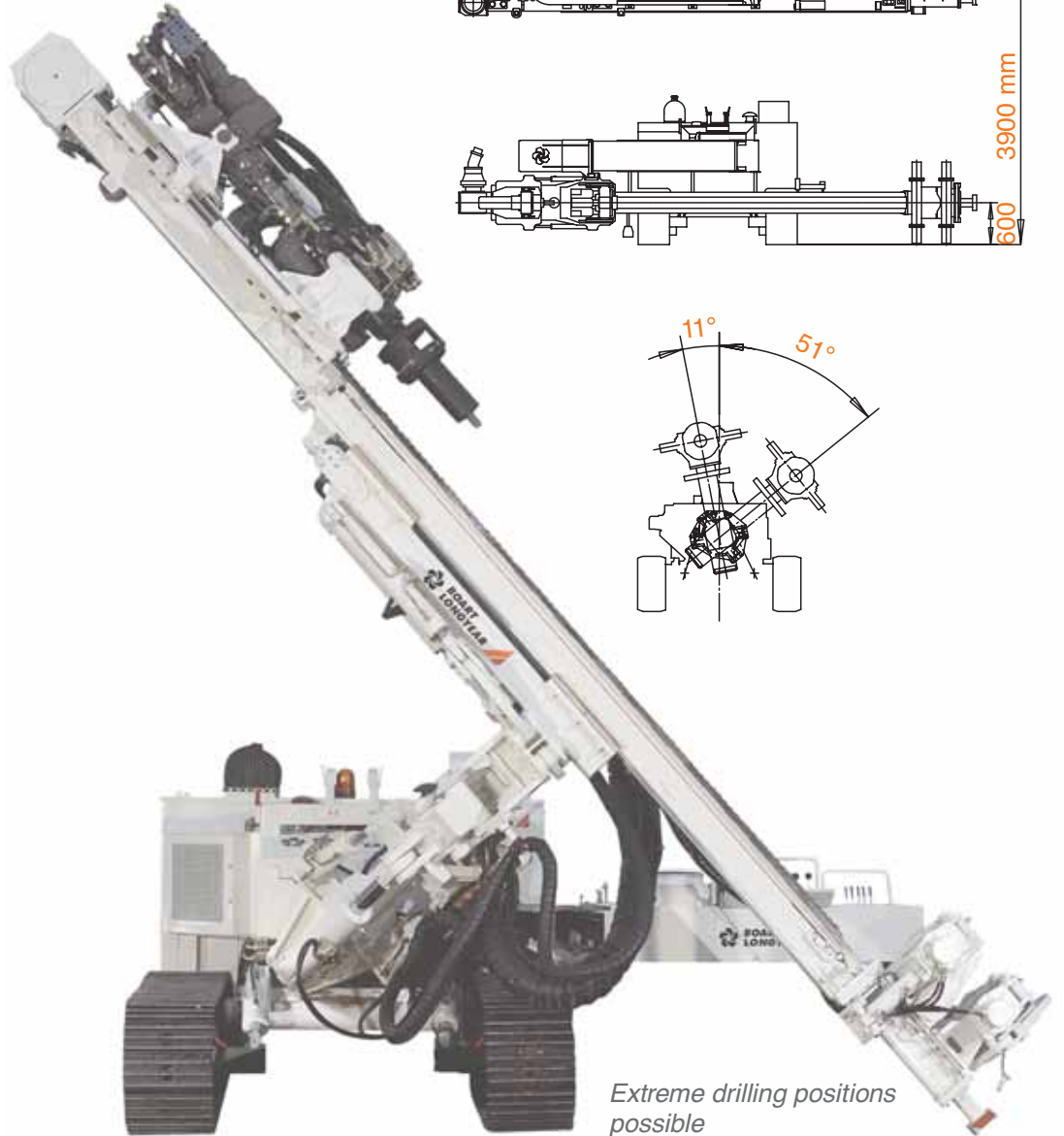
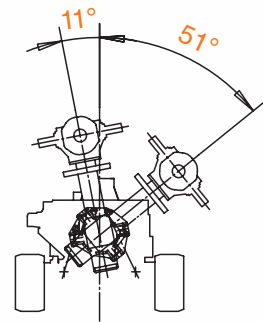
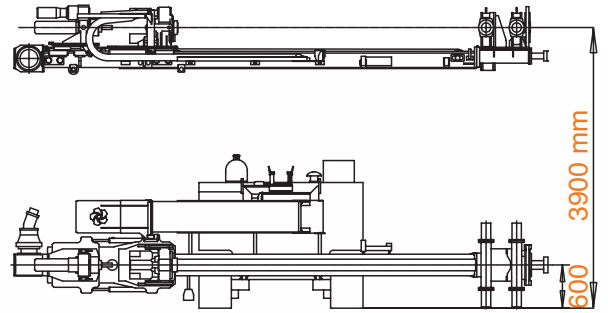
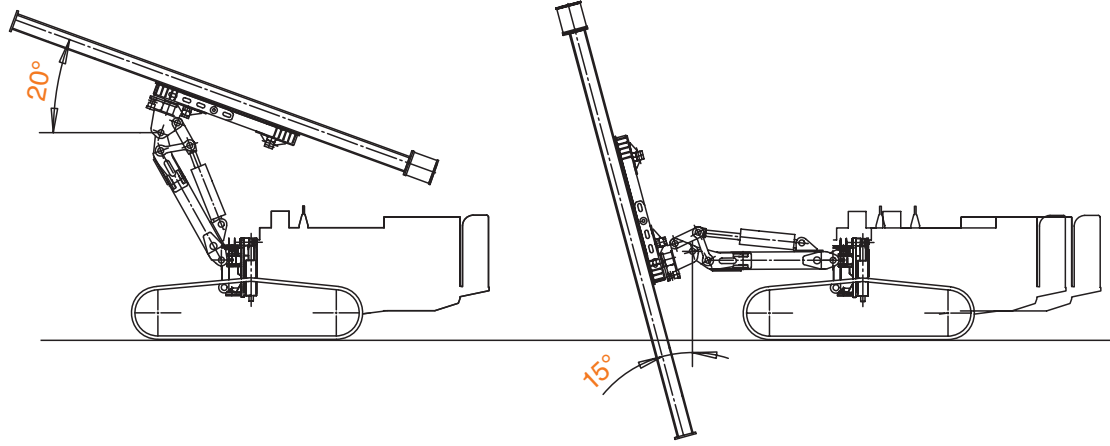

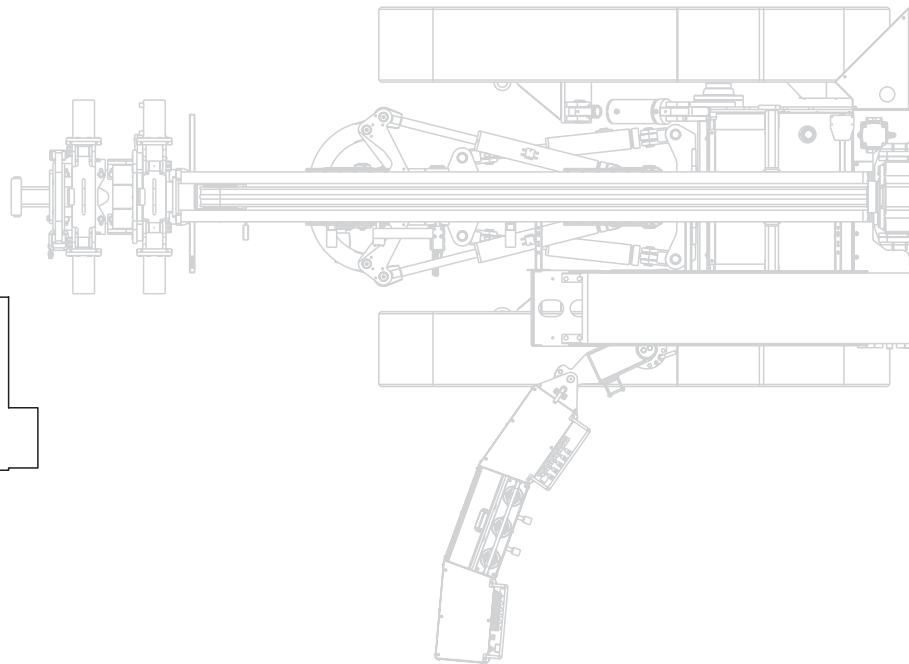
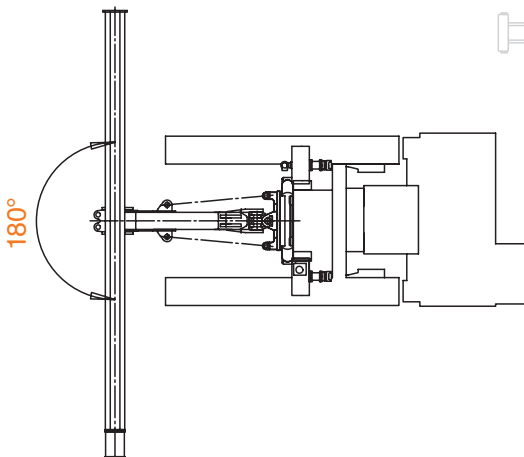
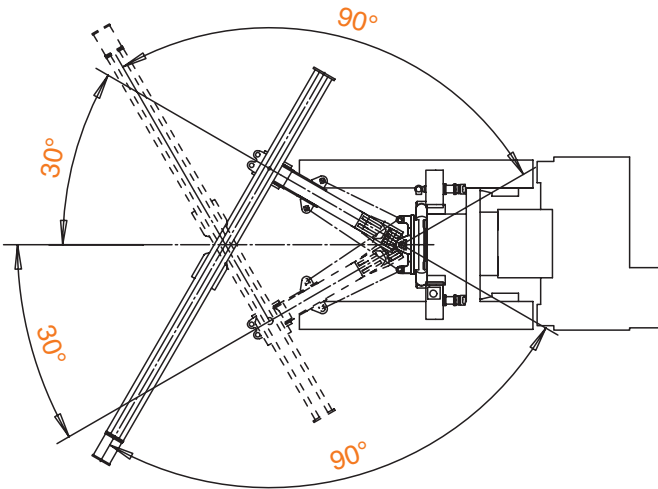
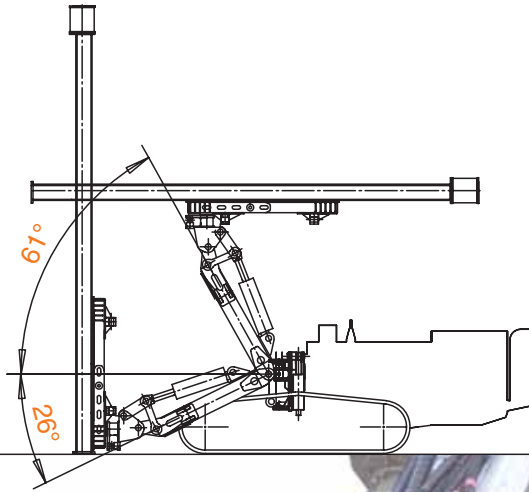
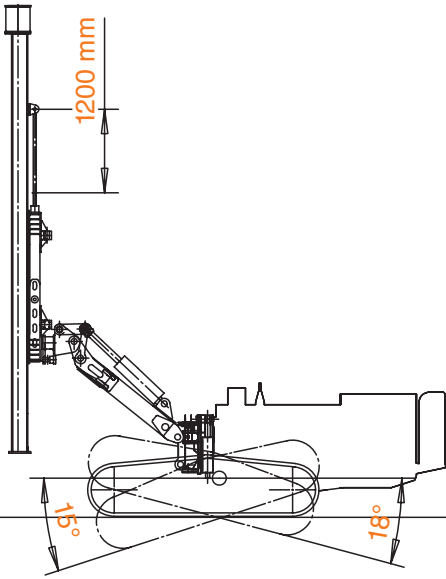

*Ergonomical control panel*



# Technical Data Delta Base 102

## Prime mover

Standard unit	DEUTZ TCD2012 L06 2V	
Fuel	Diesel	
Fuel consumption	202 g/kWh	
Power max.	147kW @ 2300 min <sup>-1</sup>	206 hp @ 2,300 rpm
Electrical circuit	24 V	
Tank capacity	260 l	68 gal

## Hydraulic system

Load sensing hydraulic system		
Main pump		
Flow rate max. Q1	300 l/min	80 gpm
Flow rate max. Q2	95 l/min	25 gpm
Gear pump		
Flow rate	25 l/min	6.6 gpm
	+40 l/min optional	+10.56 gpm optional
Pressure max.	250 bar	3,625 psi
Hydraulic oil volume	450 l	119 gal
Hydraulic cooling power	25 kW	34 hp

## Rotary heads

Torque max.	24 kNm	5,280 lbf-ft
-------------	--------	--------------

## Hydraulic drifter

Torque max.	24 kNm	5,280 lbf-ft
-------------	--------	--------------

## Double-head drilling system

Torque max.	24 kNm	5,280 lbf-ft
-------------	--------	--------------

## Drill mast and feed system

Mast with gear feed		
Divided version		
Total length including extension	6.000 mm	236.22 in
Extension mast	1.500 mm	59.06 in
Feed stroke length, double-head	3.600 mm	12 ft
Feed speed-down	15 m/min	49 ft/min
Fast feed speed-up	50 m/min	164 ft/min
Fast feed speed-down	50 m/min	164 ft/min
Pull down force	100 kN	22,470 lbf
Pull back force	100 kN	22,470 lbf

## Clamping and breaking device

Max. diameter (standard)	254 mm	10 in
Clamping sizes	from Ø45 to Ø254 mm	from 1¾ to 10 in
Max. holding force	196 kN	44,045 lbf
Break-out torque, max. torque	25 kNm	18,300 lbf-ft

## Undercarriage

Type: B2	Pendulum crawler	
Pad width	450 mm	18 in
Oscillating	+18° / -15°	
Travelling speed	2.5 km/h	1.55 mph
Climbing capability max. (without additional winch)	37% (~20°)	
Track shoes	3 web steel track shoes	

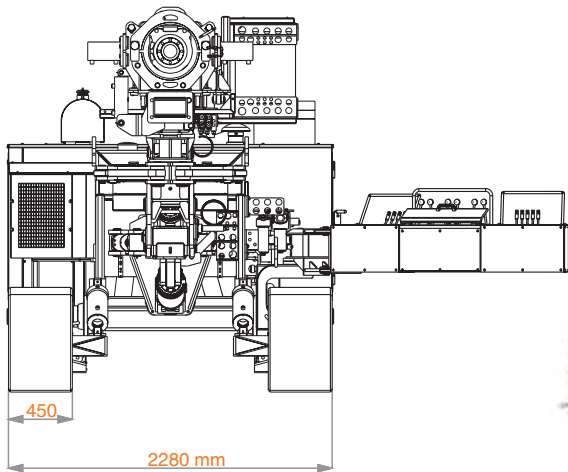
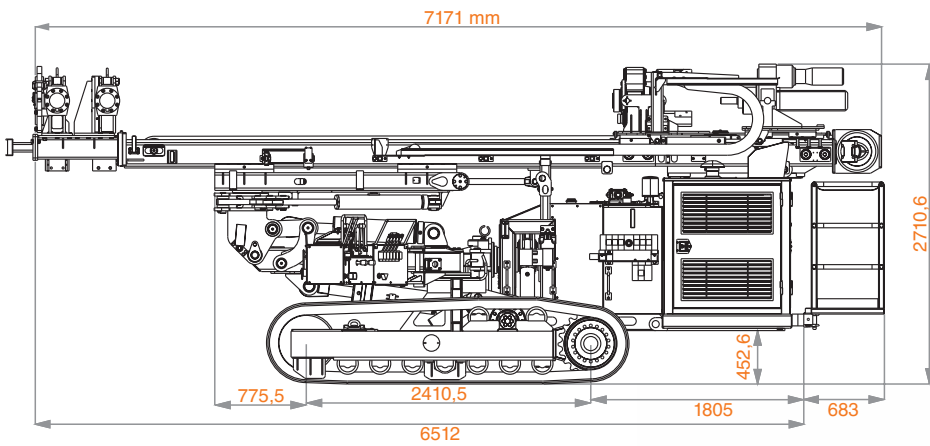
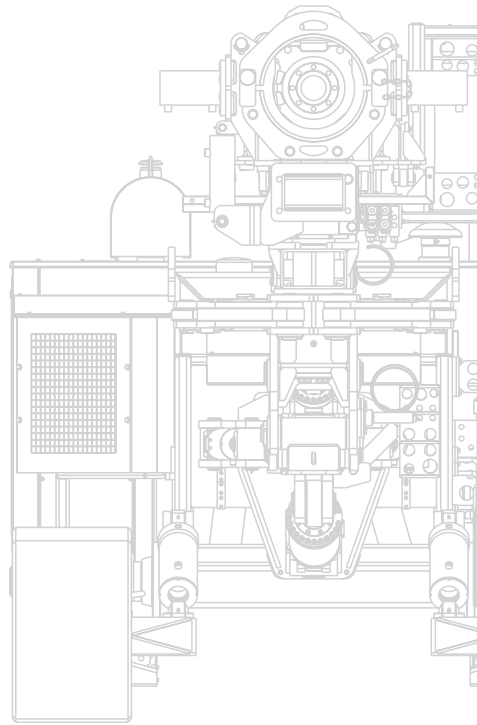
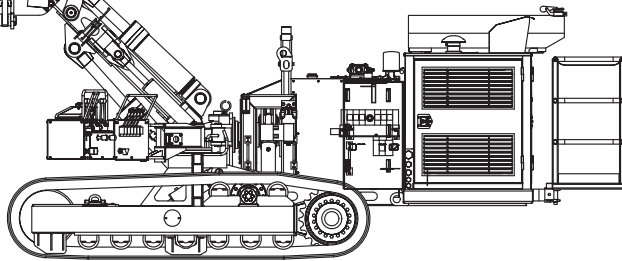
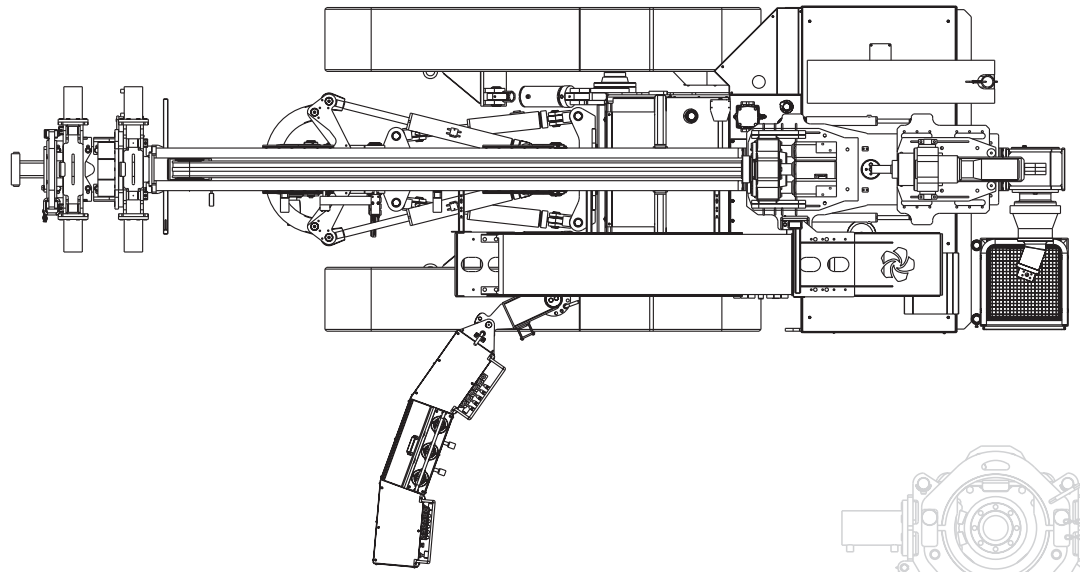
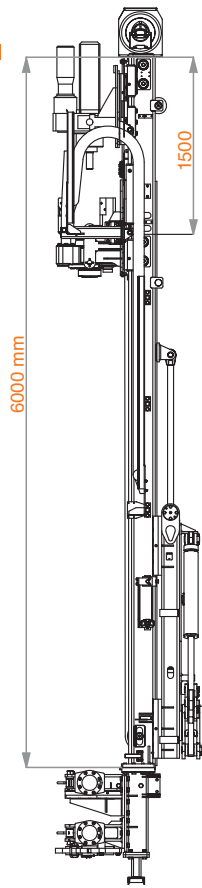

**Boart Longyear B.V.**  
**Regional Office - Europe**

Columbusweg 8  
5928 LC Venlo  
Netherlands  
T: +31 77 850 58 50  
F: +31 77 850 58 51  
E: [infoEU@boartlongyear.com](mailto:infoEU@boartlongyear.com)  
[www.boartlongyear.com](http://www.boartlongyear.com)

With compliments

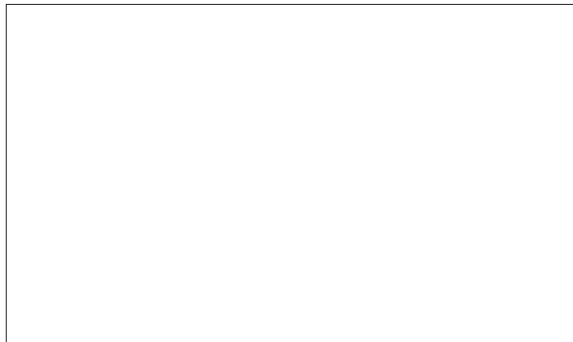

**BOART  
LONGYEAR**

Boart Longyear endeavours constantly to improve its products and therefore reserves the right to make modifications in technical versions, materials, specifications and prices without any advance notice.

DB102\_BR\_20070315\_E. © 2007 Boart Longyear